

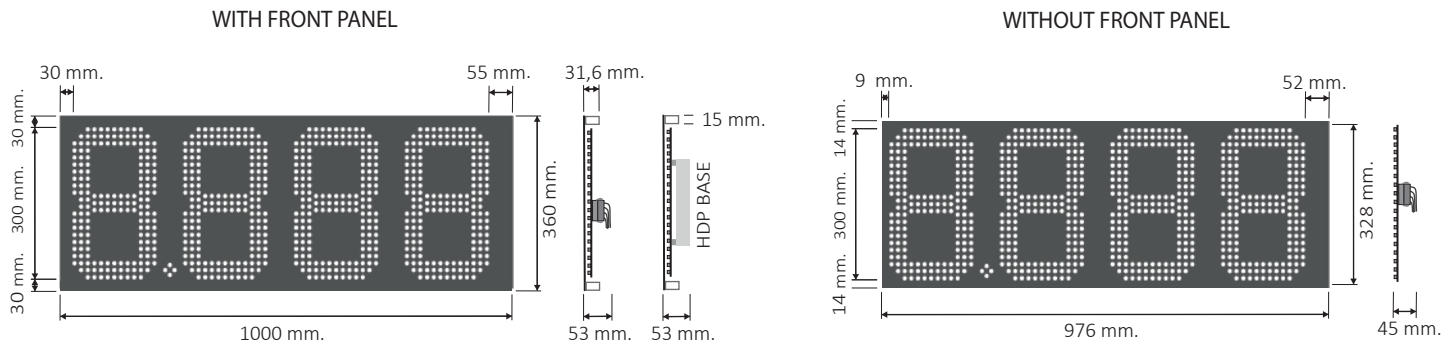

SPECIFICATIONS



Model	Code	Details
HDP30-A-WSMD-4	D 100 002384	With Front Panel , White LED
HDP30-A-RSMD-4	D 100 002394	With Front Panel , Red LED
HDP30-A-ASMD-4	D 100 002425	With Front Panel , Amber LED
HDP30-A-GSMD-4	D 100 002426	With Front Panel , Green LED
HDP30-B-WSMD-4	D 100 002427	Without Front Panel , White LED
HDP30-B-RSMD-4	D 100 002428	Without Front Panel , Red LED
HDP30-B-ASMD-4	D 100 002429	Without Front Panel , Amber LED
HDP30-B-GSMD-4	D 100 002430	Without Front Panel , Green LED

Caratteristiche tecniche

Operating Voltage	DC 15 V
Max Power Consumption	42W
IP Level	IP52
Operating Temperature Range	40 C° ~ +70 C°
Storage Temperature Range	+5 C° ~ +40 C°
Storage Environment Humidity	RH < 60%
Over-temperature protection	+75 C°
Viewing Angle	120°
No. LED	720
Life Time (temperature Tc = 75 °C)	100.000h (L70)
Warranty (See terms and conditions)	 3 years

Description

LED display with 4 digits 300 mm. height. SMD LEDs suitable for continuous operation 24h / day and exposure to UV sunlight. Printed Circuit Boards coated with a special silicone resin whose formula keeps it elastic over time avoiding cracks and infiltrations of humidity, the front panel is thermo-insulated and resistant to sunlight, for LED and components protection.

LED Characteristics

Color	Luminosity
White 6500k	3200 MCD
Amber	2270 MCD
Red	1000 MCD
Green	1200 MCD

Models without front panel

The measurements shown on this technical specification refer to models complete with front panel, for models without front panel please contact our sales department for more details.



DEFINITION OF A LED DISPLAY SYSTEM

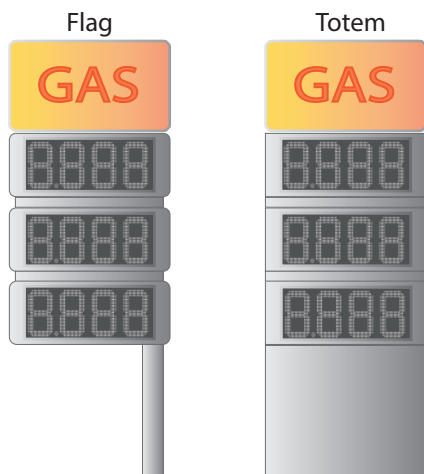

A Price System is a set of components that must be assembled and integrated into the Mini Totems, which in turn must be equipped with front windows in methacrylate or polycarbonate for the protection of the LEDs.

⚠ WARNING !! Make sure to keep a gap between the LED surface and the window glass when positioning the display.

The display can be manually or automatically programmed.

The Price System can be assembled as a single-sided version or da ouble-sided version.

How to compose a LED display system

LED DISPLAYS

Get the necessary quantity of LED displays to install on your structure.

CABLES

Select the quantity of cables required with sufficient length to connect the various LED displays to the HDP BASE controller, see on "CABLES" sheet.

HDP BASE

The standard HDP BASE controller can support up to 6 LED displays per side, for a total of 12 LED displays.

If more LED displays are needed (8 + 8 max.), It must be installed the model HDP BASE-8P, see on "ACCESSORIES" sheet.

LED DRIVER

Select the correct LED driver from the table, see on "LED DRIVER" sheet.

RDC

The 18-key remote control to program the LED displays and many other functions.

ACCESSORIES

A wide range of accessories are available and described on "ACCESSORIES" sheet.

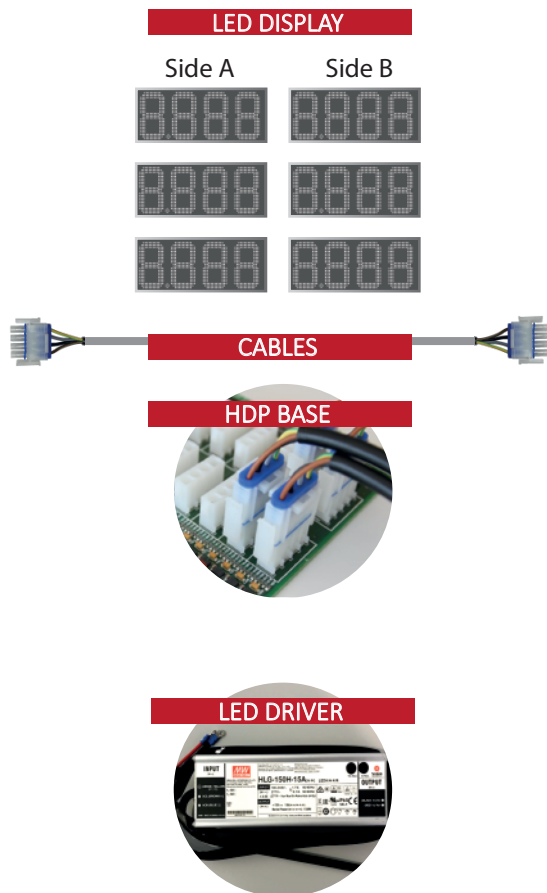

CABLES

Table of available cables to connect the various LED displays to the HDP BASE controller. The "Master display" is a display like the others, but it is considered as such because the HDP BASE controller is located behind it. All the LED displays are connected to HDP BASE, therefore the connection cable between the Master display and HDP BASE is shorter. The Master display should be installed in the lowest part of the totem.

⚠ WARNING !!

The cables must be the right length, do not let excess remain coiled up.

The cables must be fixed to structure by fastening strings, avoid leaving dangling cables because the weight would stress the connectors.



Cable lenght	Cable section	Code	Recommended
360 mm.	4 x 0,75mm	CAV 000254	Master display
1800 mm.	4 x 0,75mm	CAV 000255	
2600 mm.	4 x 0,75mm	CAV 000256	1°,2°,3° Display
4600 mm.	4 x 0,75mm	CAV 000257	4°,5° Display
5600 mm.	4 x 0,75mm	CAV 000258	6°,7°,8° Display

All price displays are connected to the HDP BASE which is located behind the Master display

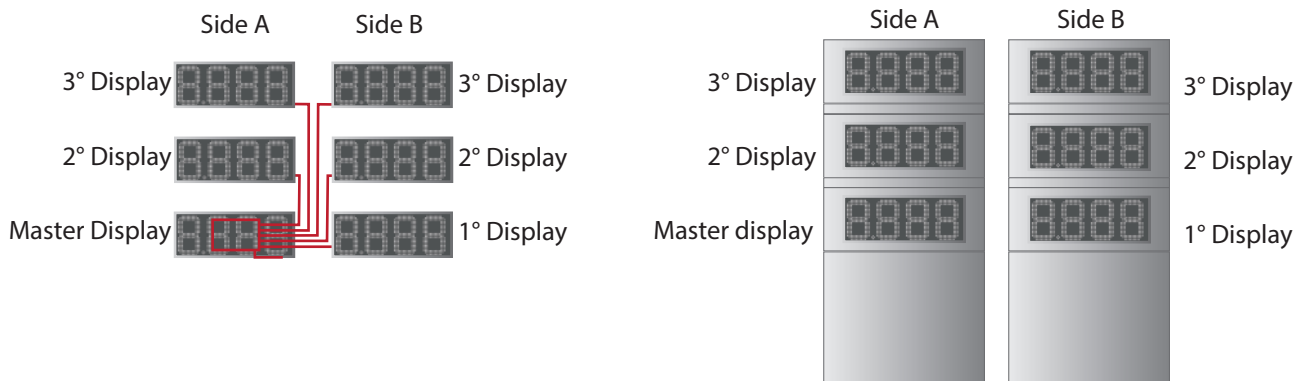

LED DRIVER

The table indicates how many and which type of LED driver are required and to which terminal blocks of the HDP BASE they must be connected. For example, a 2 + 2 system, that is 2 **HDP30** LED displays per side (double-sided), requires an **HLG-240-15** LED driver connected to the + V1-GND terminal blocks of the HDP BASE.

Code	Available LED driver models
D 100 001240	LPF-60-15 Wired
D 100 001241	HLG-150H-15A Wired
D 100 001242	HLG-240-15 Wired
D 100 001243	HLG-320-15 Wired

No. Display	Alimentatore	Morsetti su HDP BASE
1+0	LPF-60-15	+V1-GND
1+1	HLG-150H-15	+V1-GND
2+0	HLG-150H-15	+V1-GND
2+2	HLG-240-15	+V1-GND
3+0	HLG-150H-15	+V1-GND; +V2-GND
3+3	HLG-320-15	+V1-GND; +V2-GND
4+0	HLG-240-15	+V1-GND; +V2-GND
4+4	HLG-240-15	+V1-GND
	HLG-240-15	+V2-GND
5+0	HLG-240-15	+V1-GND; +V2-GND; +V3-GND
5+5	HLG-240-15	+V1-GND
	HLG-320-15	+V2-GND; +V3-GND
6+0	HLG-320-15	+V1-GND; +V2-GND; +V3-GND
6+6	HLG-240-15	+V1-GND
	HLG-240-15	+V2-GND
	HLG-240-15	+V3-GND

LED driver wiring

INPUT 220 Vac - The length of 220v input cable or wires is 300 mm.

OUTPUT 15 Vdc - The length of red and black wires is 1000 mm. The wires have a ring termination and must be firmly connected to the appropriate terminal blocks on the HDP BASE.

WARNING !!

- The two red and black output wires 15 Vdc (1000 mm.) must not be extended.
- Connection to the line 220 VAC must be carried out by qualified personnel and must be carried out in compliance with current regulations.

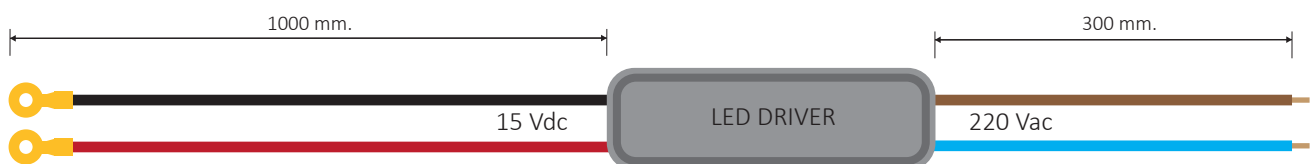

HDP BASE- CONNECTORS

The 15VDC INPUT terminal blocks named: + V1, V2, V3, V4 (positive pole) and GND (negative pole) to connect the LED drivers which are equipped with red positive and negative black wire and ring termination.

The 4-pole connectors for the LED displays are equipped with a special locking system, so you need to exert adequate pressure, making sure that it is locked correctly.

The connectors named: TWILIGHT, DISPLAY, AUX are also equipped with a special locking system as described above.

The connection to the screw terminal blocks named: ANTENNA, RS422, CURRENT LOOP must be carried out referring to the assembly instructions supplied with the product.

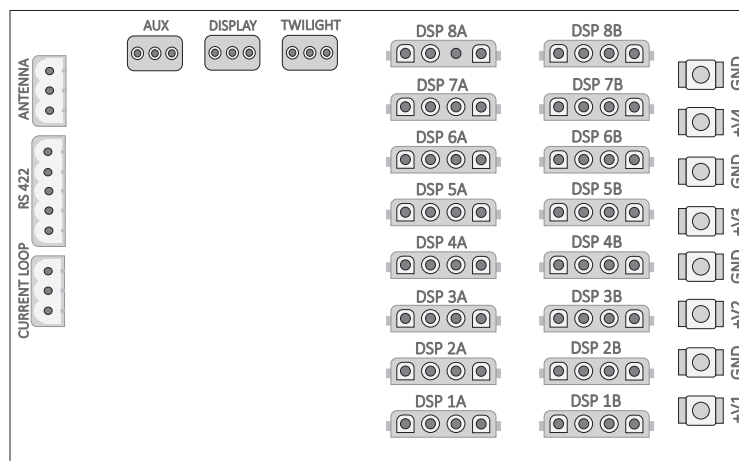

Connectors name	Function
DSP 1A.....DSP 8A	LED display connectors, only for a single side system.
DSP 1B.....DSP 8B	LED display connectors, only for the second side on a double sided system.
+V1-GND	15VDC LED driver input, to power the displays connected to DSP 1A, DSP 2A, DSP 1B, DSP 2B.
+V2-GND	15VDC LED driver input, to power the displays connected to DSP 3A, DSP 4A, DSP 3B, DSP 4B.
+V3-GND	15VDC LED driver input, to power the displays connected to DSP 5A, DSP 6A, DSP 5B, DSP 6B.
+V4-GND	15VDC LED driver input, to power the displays connected to DSP 7A, DSP 8A, DSP 7B, DSP 8B.
TWILIGHT	Optional twilight switch LS1 connection for lighting the logo, product indicators, contours, etc.
DISPLAY	Connection to graphic LCD displays for synchronized operation with price LED display.
AUX	Future use.
ANTENNA	Antenna connection for optimizing the RDC remote control signal reception.
RS 422	RS422 serial port for LAN cable connection to PC or POS with all communication protocols are available.
CURRENT LOOP	CURRENT LOOP port for connection to the POS ,this function is available only in t HDP BASE-CL or HDP BASE-8P-CL

HDP BASE- POWERING

The HDP BASE includes 4 independent banks for the LED display power (3 standard banks and the 4th bank is an optional). On each bank there are 2 terminal blocks, positive pole and negative pole 15 VDC input, to which the eyelet terminals of the LED drivers can be screwed as well as 4 connectors (A side and B side) to which the LED displays can be plugged.

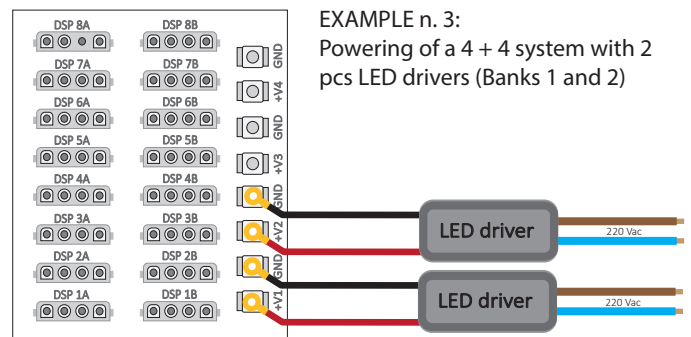
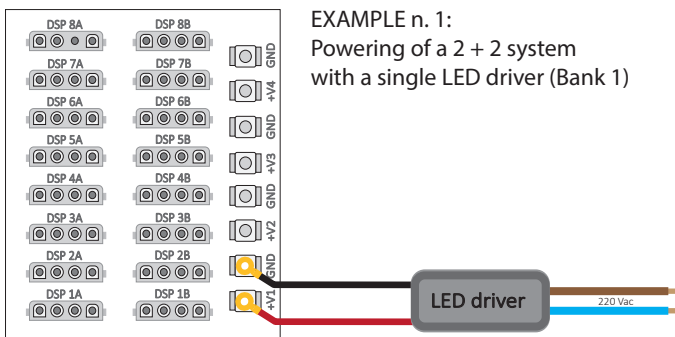
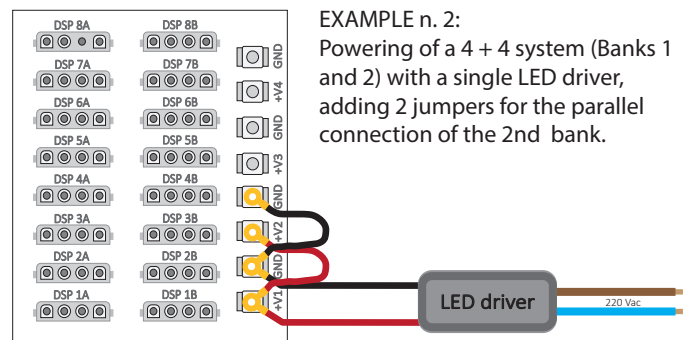
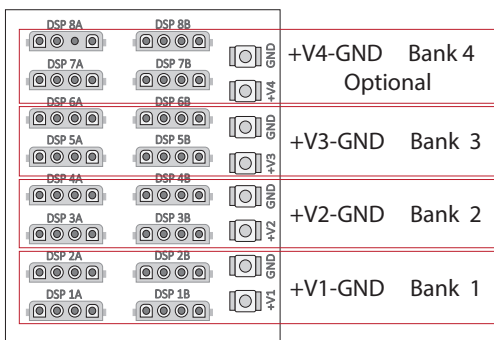

The two jumpers: positive (red wire) and negative (black wire) are used to connect 2 banks in parallel to the same LED driver.

Code	Available jumpers
CAV 000681	Red wire jumper
CAV 000680	Black wire jumper

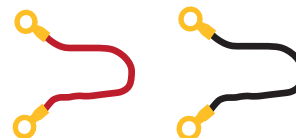

⚠ WARNING !!

- The terminal block screws must be tightly screwed to avoid overheating due to high current (A)

PROGRAMMING



Remote RDC

18-key remote control, 10-50 m range for manual programming of fuel prices and various setting functions.

Keyboard CT100

The CT100 LCD keypad allows you to program fuel prices and manage messages from text or graphic panels, or it can become transparent allowing programming directly from POS, or both modes at the same time, use category 5 LAN cable (max. cable length: 1000m).

Wired PC

Programmation of one or more LED display systems by PC through category 5 LAN cable (max. cable length: 1000m), suitable for use with the LED PROG software, the remote control can be used at the same time. If necessary, add CONV-SU01 for RS422 serial, or TCPIP for RS485 serial.

Wired POS

Programmation of one or more LED display systems by POS through category 5 LAN cable (max. cable length: 1000m), all protocols are available, the remote control can be used at the same time. If necessary, add CONV-SU01 for RS422 serial, or TCPIP for RS485 serial.

Wireless PC

Programming of one or more LED display systems from POS via radio modem WT868 and WR868, the range is 80m in open field and up to 800m in open field with the addition of the yagi antenna. Suitable for use with LED PROG software, the remote control can be used at the same time.

Wireless POS

Programmation of one or more LED display systems by POS through the CUPW868 wireless control unit and WR868 radio modem, the range is 80m in open field and up to 800m in open field with the addition of the yagi antenna. All protocols are available, the remote control can be used at the same time.

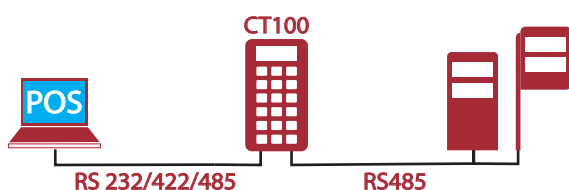

AVAILABLE COMMUNICATION PROTOCOLS



- PC LEDPRO
- HITECH 1200Hz
- OMV



- TOKHEIM KA (KOPPENS AUTOMATIC) ver. 4.2
- TOKHEIM JUPITER ST 39



- PROEDA V21-02-01/CK



- LOGITRON GILBARCO 70RPLSUPSIT.E04 (PASSPORT EUROPE)
- ENI
- GILBARCO ESTESO



- SCHEIDT & BACHMANN V11



- SCHENK 68000/68020 ver.2.02 2400 BAUD RATE
- SCHENK 68000/68020 ver.2.02 4800 BAUD RATE



- WAYNE DRESSER SYSTEM MARKETER PIGNONE SM2000/3000
- WAYNE DRESSER NUCLEUS 8 (1200 BAUD RATE MONODIREZIONALE)
- WAYNE DRESSER NUCLEUS 9 (9600 BAUD RATE BIDIREZIONALE)
- HITECH_PIGNONE-TON1070S
- ENI
- WAYNE DRESSER ESTESO BIDIREZIONALE



- IFSF LON WORK (It needs an additional interface)



- MASER AUTOMATION



- LAFON - MAGIC 2000



- FORTECH



- ALVIC

ACCESSORIES

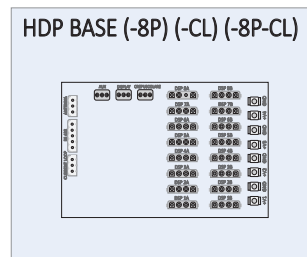
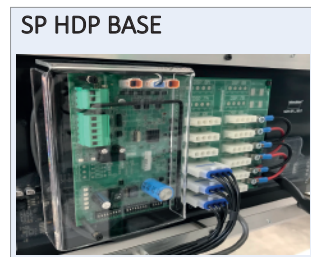

Code	Models	Description
D 100 001032	RDC	Remote control
D 100 002322	CT100	LCD keyboard
D 100 002200	CONV_SU01	USB - RS422 converter
O 100 003023	TCPIP	Interface RS485/USB - LAN
D 100 002271	WT868	Tx Radio modem
D 100 002272	WR868	Rx Radio modem
D 100 002164	CUPW868	Wireless control unit

Code	Model	Description
D 100 002285	YAGI868	Yagi Antenna
D 100 002284	LS1	Twilight switch
D 100 002336	SP HDP BASE	Protective shield for HDP BASE
D 100 001255	HDP BASE-8P	8+8 LED display version
D 100 001257	HDP BASE-CL	Current loop version
D 100 001258	HDP BASE-8P-CL	8+8 and current loop version
O 091 000405	ANT433-4	Additional antenna for RDC

** These options must be requested when ordering, cannot be added after sale.

QUALITY

Protective coating

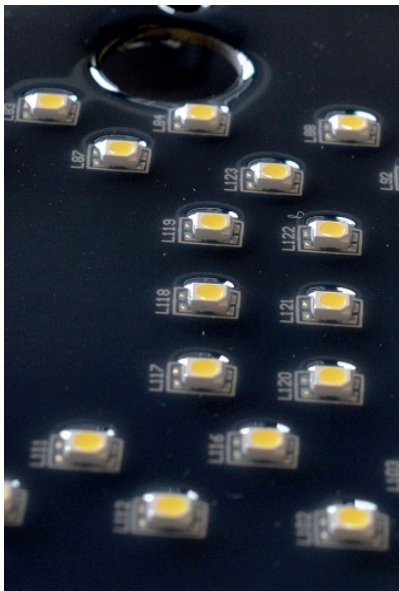

The considerable thermal excursion and the high moisture to which the LED displays are subjected, driven Hitechled design department to prefer a protection of the electronic boards made of pure silicone. This material, unlike common protective resins, has the advantage of always remaining elastic and unaltered over time, avoiding cracks and related moisture infiltrations.

The dosage of this precious material is performed by automatic machines, avoiding to deposit sediments on the surface of the LEDs.

Sealed connectors

The rugged connectors designed for the industrial sector are equipped with protective silicone seals into the gap between the male and female socket and in the collars around the wires. The safety lock ensures a stable connection, thus avoiding malfunctions due to hasty wiring. The contacts coated with anti-oxidation metal are suitable for use in humid environments and guarantee a considerable duration over time.

LEDs controlled by constant current drivers

LED displays are equipped with constant current drivers, furthermore the LEDs are divided into many branches and connected together in series of only 4 units, this serves to minimize the problem of illegibility in the event that a spoiled.

The brightness of the LEDs is automatically adjusted by the microprocessor integrated in each single digit with PWM (Pulse With Modulation) procedure.

Overheating protection for LEDs

An integrated temperature micro-sensor reduces the current in the LEDs in case of ambient overtemperature, then bringing it back to the normal level with the restoration of the temperature values below the limit, this automatic system serves to avoid premature aging of the LEDs, allowing them to age in accordance with the manufacturer's expected derating curve in the 100,000 hours of operating life of the LEDs.



QUALITY

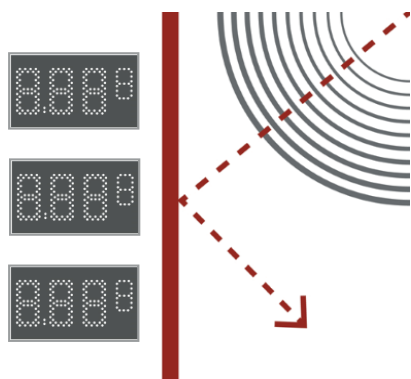

Sturdy wiring and high immunity to interference

The connection between the HDP BASE and the LED displays consists of a single cable with 4 wires (double insulation) and therefore mechanically robust, so the cables can be fixed to the structure by fastening strings.

The HDP BASE is equipped with 16 independent RS485 serial communication channels, one for each single LED display which are each equipped with a microprocessor that decrypts and correctly displays the prices arriving from the HDP BASE. The hardware thus designed in addition to the software filters of the main microprocessor makes communication extremely safe and immune to electromagnetic disturbances, avoiding to display of wrong or deformed characters.

Opto Isolated communication serial port

The optical device for the galvanic separation of the RS422 / 485 communication serial port included on the HDP BASE, establishes a very high level of immunity to electrical discharges induced in the cable towards the POS.



Resistance to solar radiation and temperature

All the LED displays are equipped with a sunshade front in non-deformable in fiber-glass which being a poor conductor of heat, plays a role of heat shield and protection from the effects of solar radiation as well as finishing the display.

Brightness sensor on each LED display

Each individual LED display is equipped with a brightness sensor, all the displays connected to the DSP 1A ... DSP 8A connectors measure continuously the amount of ambient light and send this value to the HDP BASE board, consequently the brightness of the all LED display connected to HDP BASE (A side and B side) is automatically adjusted, optimizing consumption and making the reading of the displays more comfortable.